

Conveyors



- ▶ Sanitary design
- ▶ Custom fit chutes and hoppers
- ▶ Adjustable legs on casters
- ▶ Removable belt and rails for easy cleaning
- ▶ Optional drive allows for output control



CONVEYOR TECHNICAL SPECIFICATIONS

(DRAWING AND SPECS SHOWN ARE TYPICAL BUT ARE SUBJECT TO CHANGE)



LOW-MAINTENANCE WASHDOWN PULLEY MOTOR



FITTED HOPPER MINIMIZES PRODUCT LOSS

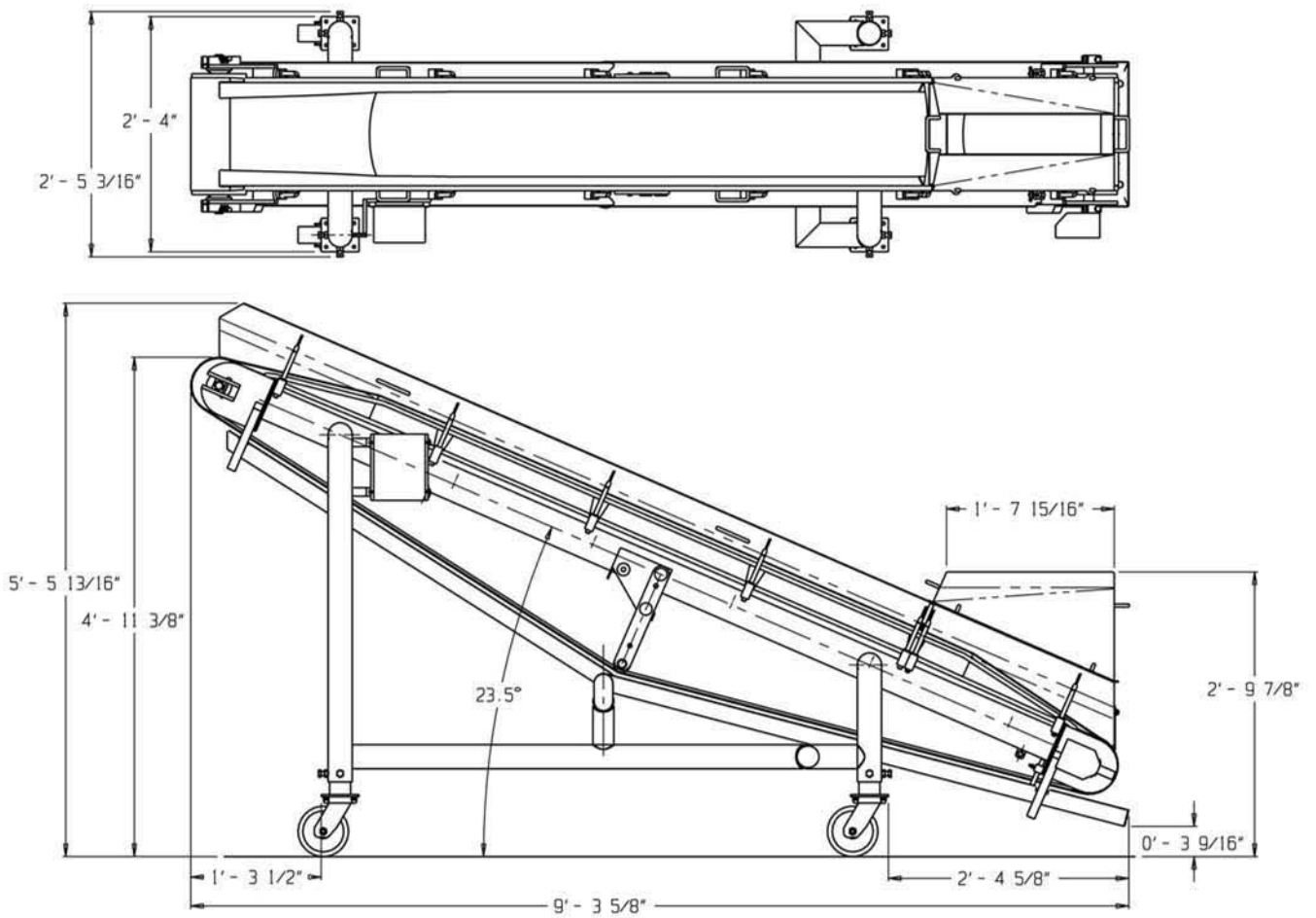

CERTAIN MEASUREMENTS CAN BE MODIFIED TO SUIT YOUR SPECIFIC NEEDS