



- ▶ Produces clean-cut, uniform dices, strips, shreds and slices.
- ▶ Quick release system for the cutting spindles allows fast changeover from one cut size to another.
- ▶ Sanitary design makes cleanup quick and easy.
- ▶ Hinged in-feed and discharge chute facilitate access to the machine and ensure thorough and quick cleaning possibilities.
- ▶ Interlocking safety switches on guards and protective covers.

**TYPE OF CUTS:**

*First cut: Slices thickness adjustable from 1/16" to 5/8" or 1.5mm up to 15mm*

*Second cut: Strips (with circular knives): 1/8" to 5/8" or 3.2mm up to 15mm*

*Third cut: Dices (with crosscut knives): 1/8" to 5/8" or 3.2mm up to 15mm*

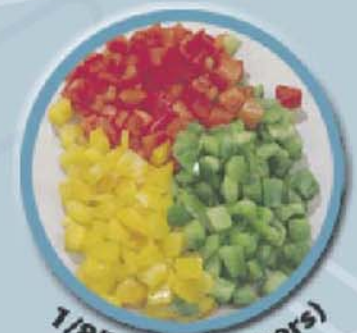

**1/8" dice (peppers)**



**1/8" dice (meat)**



**1/8" julienne (cheddar)**



**1/4" dice (fruit)**

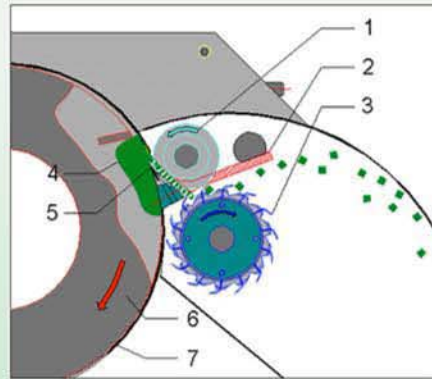

1. Circle knife spindle assembly
2. Shear plate
3. Crosscut knife assembly
4. Product
5. Slicing knife
6. Impeller
7. Drum

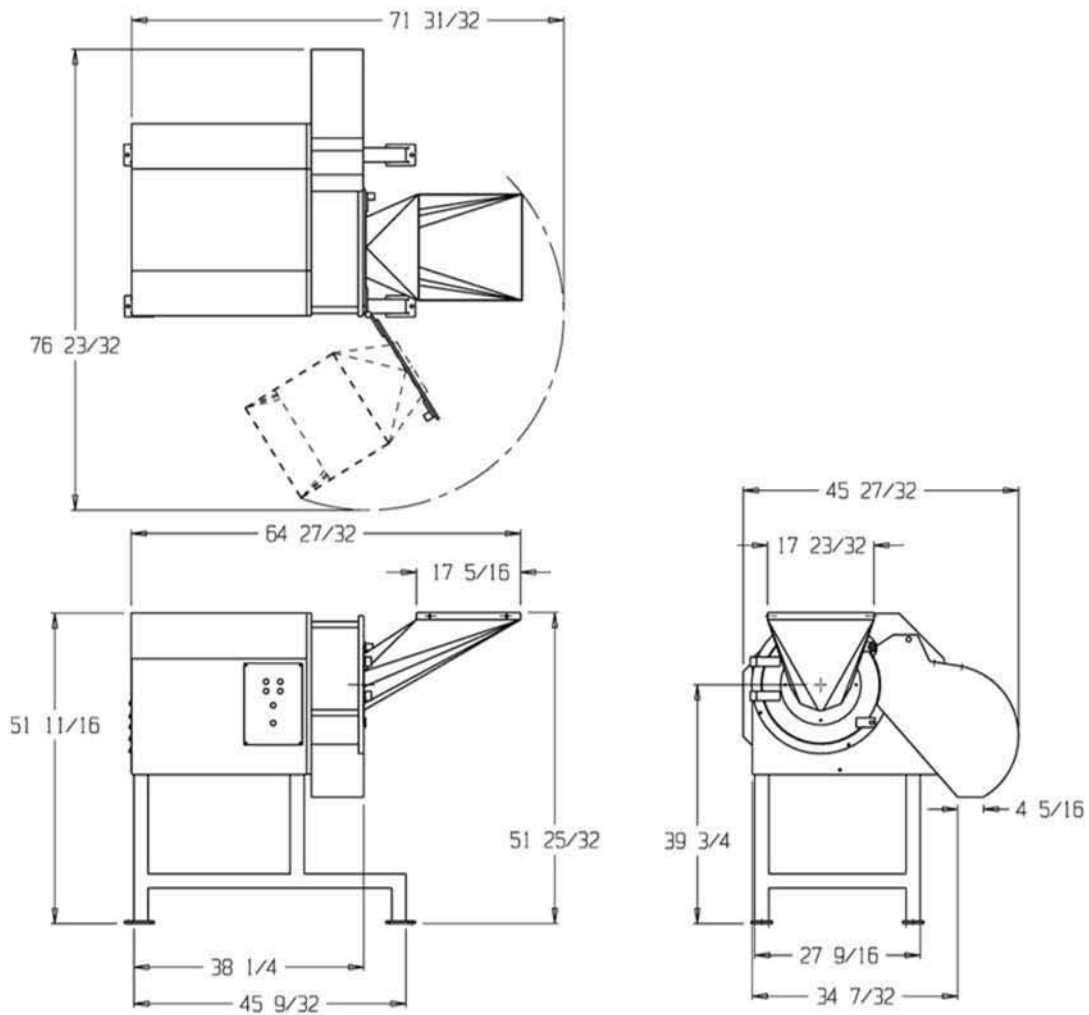

Length: 1646mm (64,80")  
 Width: 1067mm (42")  
 Height: 1555mm (61,22")

Net weight: 300kg (660lbs)  
 Motor: 5,5kW (7,5HP)  
 Capacity: 1600kg/hour (3520 lbs/hour)