



DEVILLE  
TECHNOLOGIES

## FS40 (Automatic) Shredder/Grater/Crumbler



- ▶ High-capacity up to 14,000 pounds or more per hour.
- ▶ USDA and WDATCP accepted.
- ▶ Automatically feeds whole or multiple cheese blocks.
- ▶ No pre-cubing of blocks required, maximizing productivity and minimizing labor.
- ▶ Inexpensive and re-usable cutting discs.
- ▶ 15 or 20 hp motor with variable speed available.
- ▶ All components are quick-release for fast set-up or dismantle and easy sanitation and maintenance.
- ▶ PLC controlled and interface capable with upstream and downstream processes.
- ▶ Crafted with state-of-the-art patented technology.

### **TYPE OF CUTS:**

*Produces precise cuts in sizes ranging from 5/64" to 1" including:  
feather cuts, flakes, crumbles, "v" cuts, grates and custom specialty cuts as required.*



feather cut (cheddar)



flake (parmesan)



crumble (feta)



v-cut (swiss)

514.366.4545

[www.cheeseshredder.com](http://www.cheeseshredder.com)

# FS-40 (Automatic) TECHNICAL SPECIFICATIONS



Removable precut blades  
to adjust length



Quick and easy shred  
disc changeover

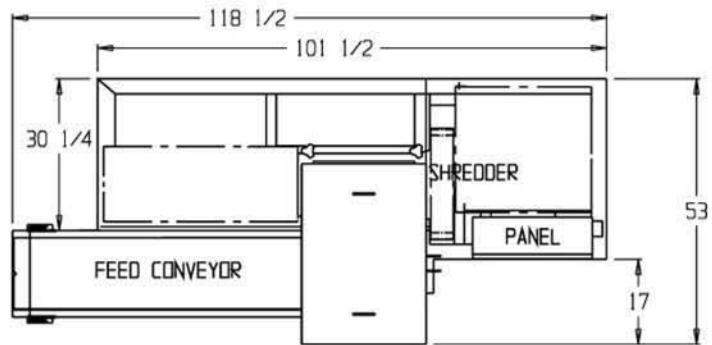

TOP VIEW

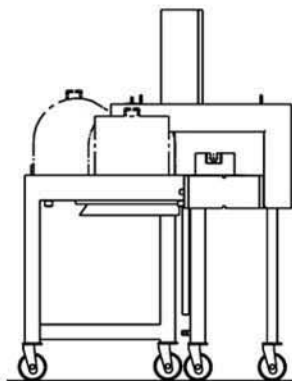

SIDE VIEW

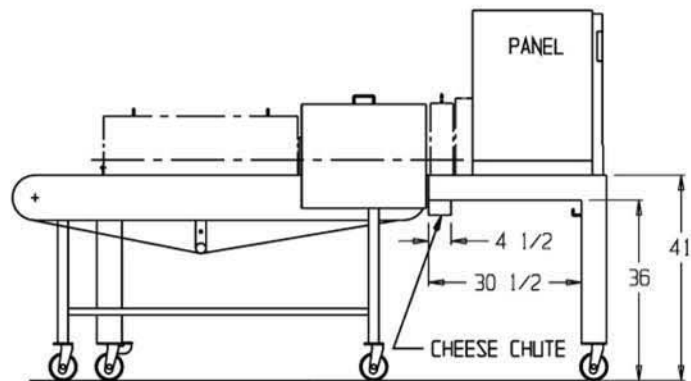

FRONT VIEW

Length: 3010mm (118 1/2")  
Width: 1346mm (53")  
Height: 1880mm (74")

Net weight: 1134kg (2500lbs)  
Motor: 11kW (15HP) or 15kW (20HP)  
Capacity: 6350kg/hour (14000 lbs/hour)